

**NEW**

# 10+Gbps 0.8mm pitch Board to Board Connectors

## FX18 Series

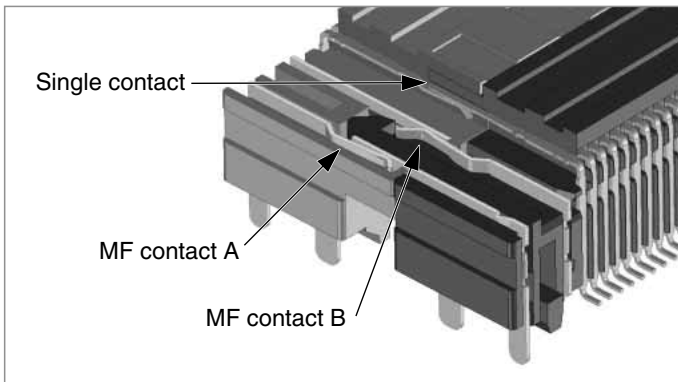

### ■ Mechanical features

- **0.8mm Pitch**
- **Variations :Coplanar / Vertical**
- **Number of Contacts : 40 / 60 / 80 / 100 / 120/ 140**
- **Multi functional contact (MF contact) as;**
  - ground contact to enhance grounding.
  - power supply contacts up to 12 A to reduce required pin counts.
  - 3-step sequential contacts for grounding and detection.
- **Effective mating length of signal contact: 2.0 mm.**  
(MF contact A:2.5mm / MF contact B:1.5mm)
- **Pin through hole mounting MF contacts increase strength against wrenching.**
- **Large mating guide for easy mating.**

### ■ Signal integrity features

- **Insertion Loss-to-Crosstalk-Ratio (ICR)**  
The insertion loss-to-crosstalk ratio (ICR) with five-aggressor differential FEXT meets the extrapolated IEEE802.3ap specification for 10+Gbps with plenty of margins.
- **Differential Impedance**  
The differential impedance is within  $100 \pm 10$  ohms at 35 ps rise time( 20% to 80%)

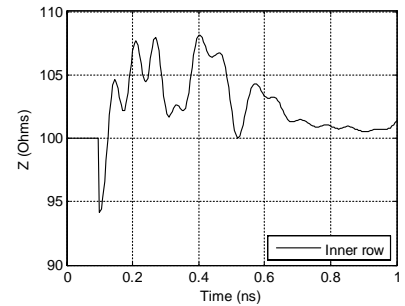
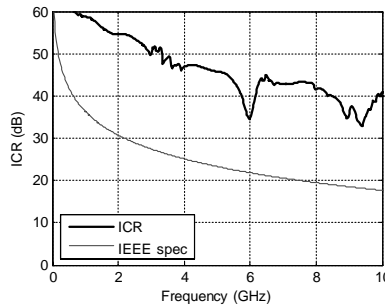

### ■ Variations

#### Coplanar connection

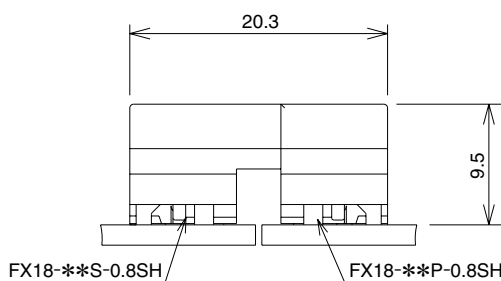

#### Vertical connection

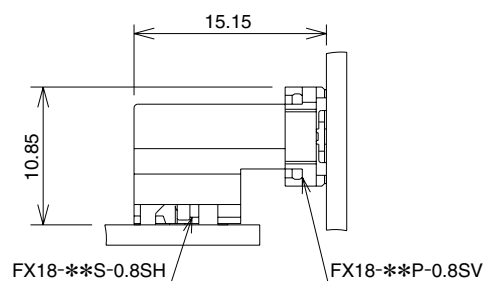

## ■Product Specification

Rating	Current Rating 0.5A(Signal) (Note3) 3.0A(MF contact )	Operating Temperature Range -55℃ ~ 80℃ (Note 1)
	Voltage Rating AC100V	Storage Temperature Range -10℃ ~ 60℃ (Note 2)

Item	Specification	Condition
1.Contact Resistance	90m ohms max	100mA
2.Insulation Resistance	1000M ohms min	250V DC
3.Voltage Proof	No flashover or insulation breakdown	300V AC / 1min
4.Durability (mating/unmating)	Contact resistance: 100m ohms max	500 cycles
5.Vibration	No electrical discontinuity of 1μs or more	Frequency:10 to 55Hz, Approx 5 min Single amplitude0.75mm, 10cycles for 3 directions
6.Shock	No electrical discontinuity of 1μs or more	490m/s <sup>2</sup> ,Duration of pulse 11ms, at 3 time for 3 directions
7.Humidity (Steady state)	Contact Resistance :100m ohms max Insulation Resistance: 1000M ohms min	96 hours at temperature of 40±2℃ and humidity of 90% to 95%
8.Temperature Cycle	Contact Resistance :100m ohms max Insulation Resistance: 1000M ohms min	(-55℃:30 minutes,85℃:30minutes) under 5 cycle

(Note 1) Includes temperature rise caused by current flow.

(Note 2) "Storage" means a long-term storage state for the unused product before assembly to pcb.

(Note 3) The rated current applies to per contact.

(Note 4) Information contained in this catalog represents general requirements for this Series. Contact us for the drawings and specifications for a specific part number shown.

## ■Material

### ●Receptacle / Header

Part	Material	Finish	Remark
Insulator	PA	Black	UL94V-0
Signal contact	Phosphor bronze	Contact area:Gold plated Lead area :Gold plated	——
MF contact	Phosphor bronze	Contact area:Gold plated Lead area :Tin plated	——

## ■Ordering Information

### ●Right Angle Receptacle

**FX18 - 60 S - 0.8 SH**  
① ② ③ ④ ⑤

### ●Right Angle Header

**FX18 - 60 P - 0.8 SH**  
① ② ③ ④ ⑤

### ●Straight Header

**FX18 - 60 P - 0.8 SV**  
① ② ③ ④ ⑤

① Series Name	:FX18
② Number of contacts	
③ Connector Type S	:Receptacle P :Header
④ Contact Pitch	:0.8mm
⑤ Contact Type	SH :Board Right Angle Type SV :Board Straight Type

## Function Chart

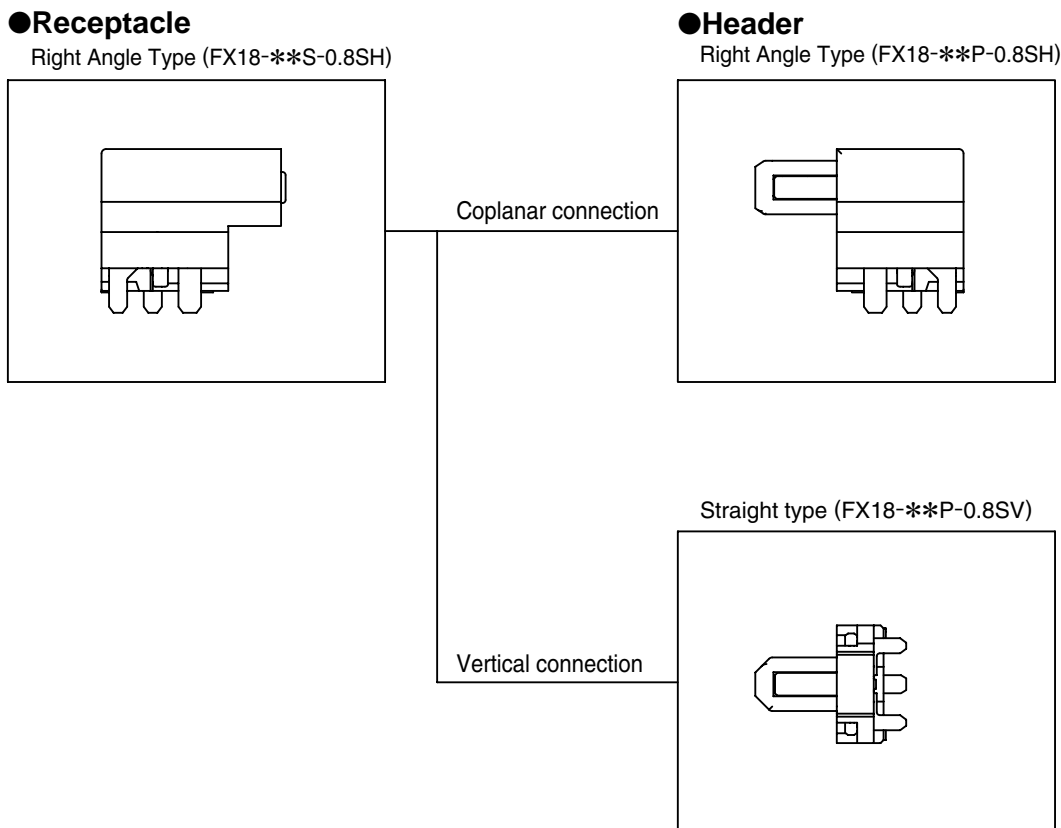

## Signal Integrity

### ●Pin assignment

To match 100 ohm differential impedance and to reduce crosstalk, a staggered GSSG pin assignment is recommended for FX18. (G=ground and S=signal)

### Pin assignment ( In case of 40 pos. )

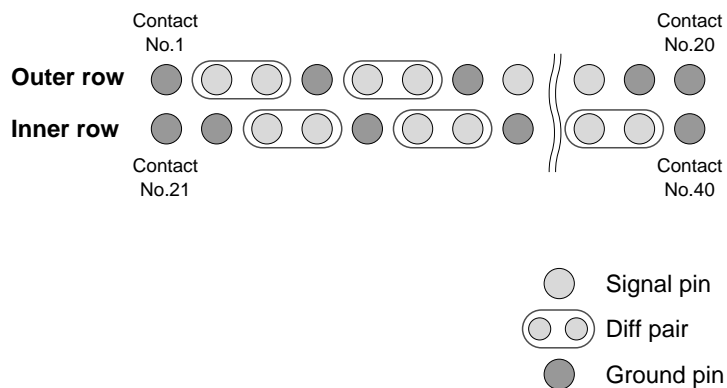

### Cross section of mating (coplanar connection)

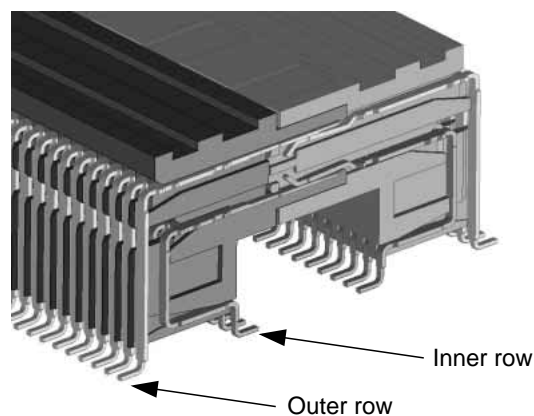

## ● Impedance

The differential impedance is  $100 \pm 10$  ohm for FX18 at 35 ps rise time (20% to 80%)

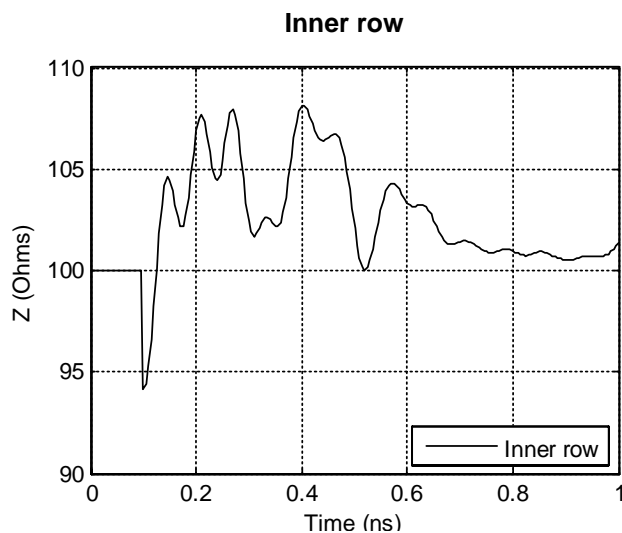
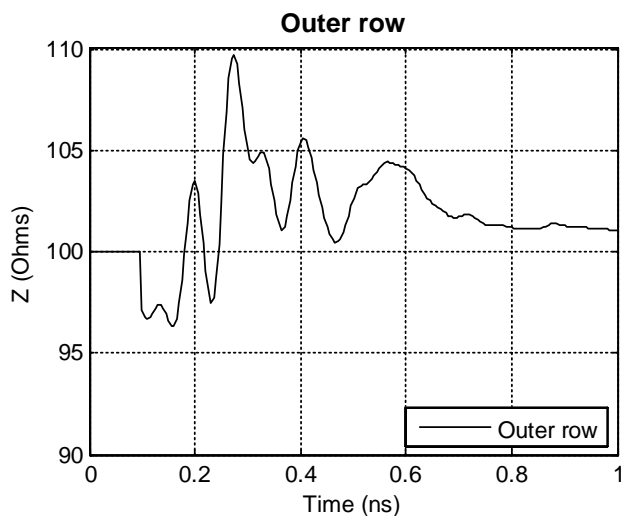

## ● Insertion Loss

The differential insertion loss crosses 1dB at 6GHz for FX18.

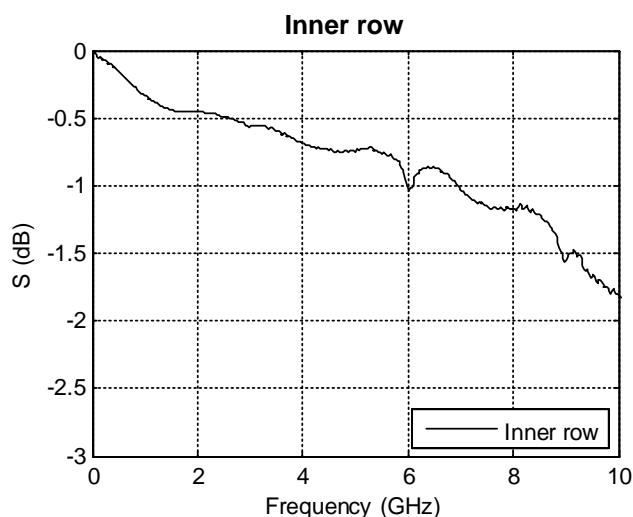
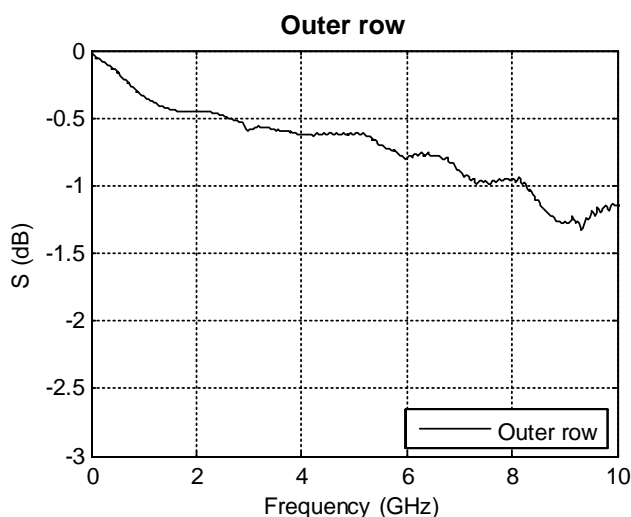

## ● Return loss

The differential return loss meets the IEEE 802.3ap specification to 10 GHz for FX18.

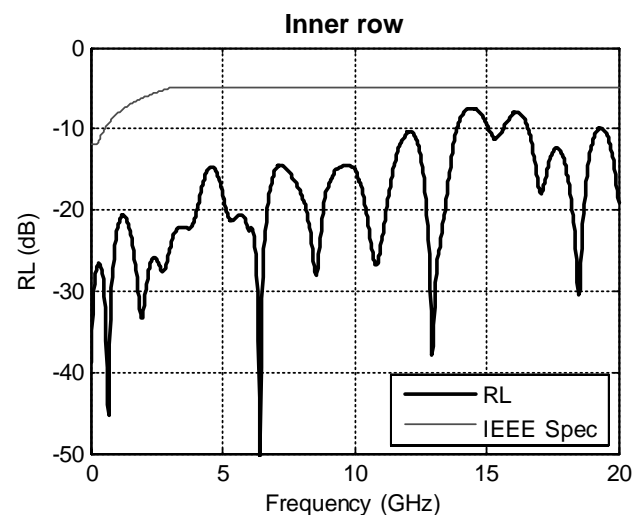
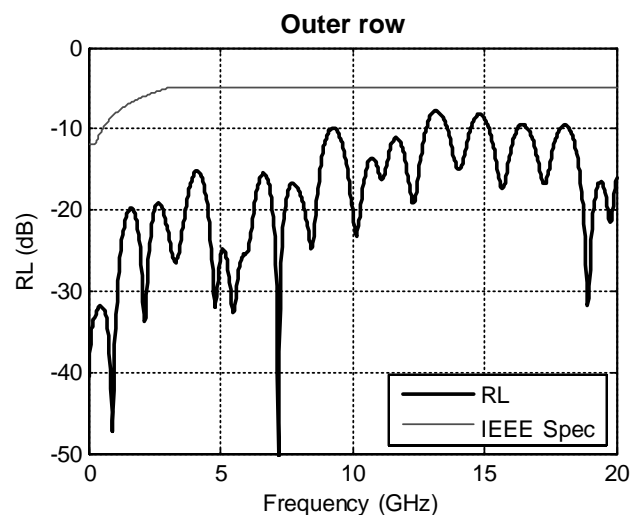

### ●Near-end crosstalk (NEXT)

The staggered GSSG pin assignments resulted in low differential NEXT.

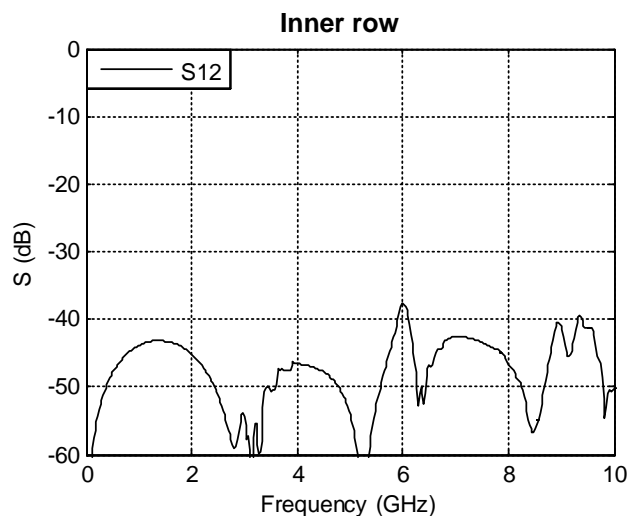
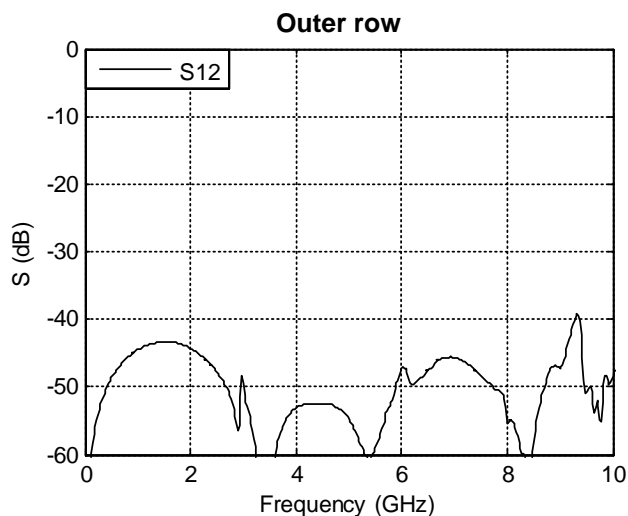

### ●Far-end crosstalk (FEXT)

The staggered GSSG pin assignments resulted in low differential FEXT.

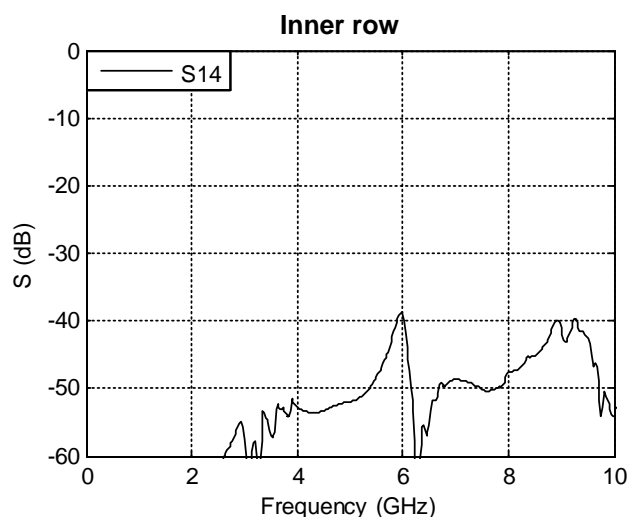
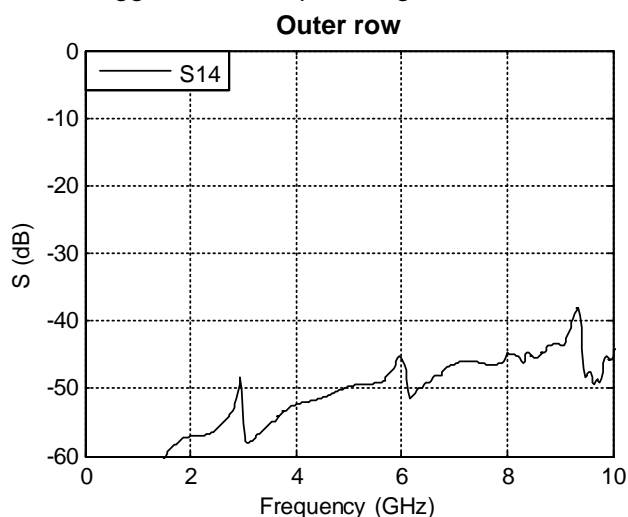

### ●Insertion-loss-to-crosstalk ratio (ICR)

The insertion-loss-to-crosstalk ratio (ICR) with multi-aggressor differential FEXT meets the extrapolated IEEE 802.3ap specification to 10+Gbps with plenty of margins.

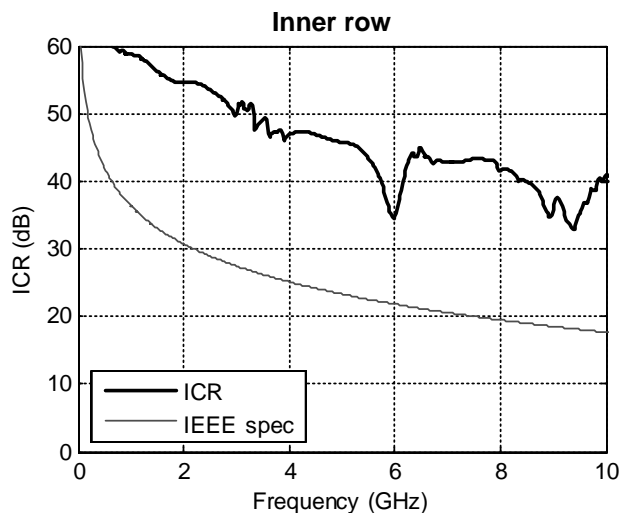
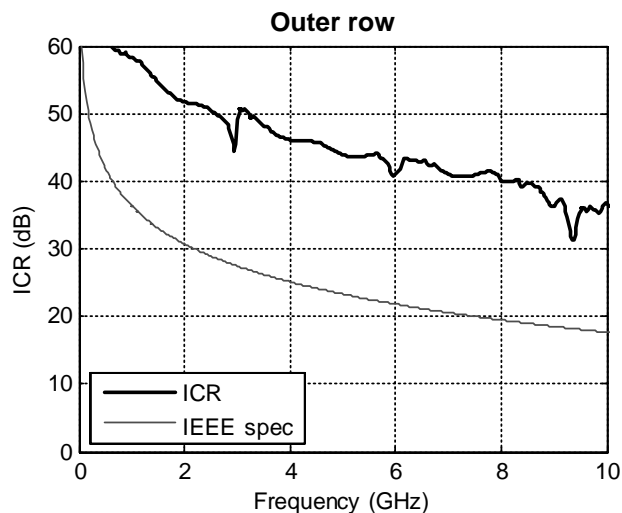

## Right Angle Receptacle

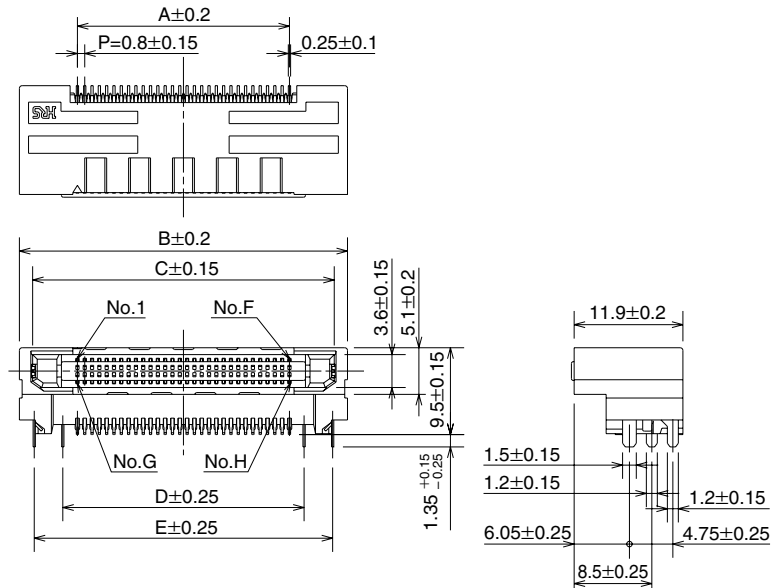
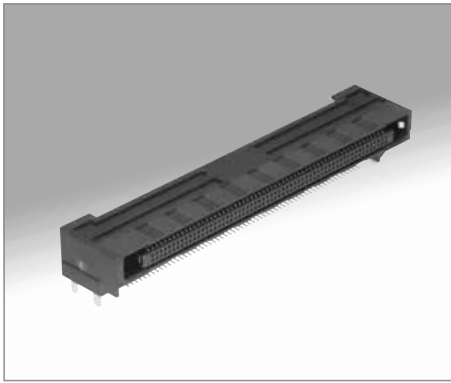

All dimensions in mm

Part Number	HRS No.	A	B	C	D	E	F	G	H(pos.)
★ FX18-40S-0.8SH	CL579-0009-4	15.2	27.9	25.0	18.4	24.65	20	21	40
★ FX18-60S-0.8SH	CL579-0010-3	23.2	35.9	33.0	26.4	32.65	30	31	60
★ FX18-80S-0.8SH	CL579-0011-6	31.2	43.9	41.0	34.4	40.65	40	41	80
FX18-100S-0.8SH	—	39.2	51.9	49.0	42.4	48.65	50	51	100
★ FX18-120S-0.8SH	CL579-0013-1	47.2	59.9	57.0	50.4	56.65	60	61	120
FX18-140S-0.8SH	—	55.2	67.9	65.0	58.4	64.65	70	71	140

★ indicates "available". No marking, "under development"

## Right Angle Header

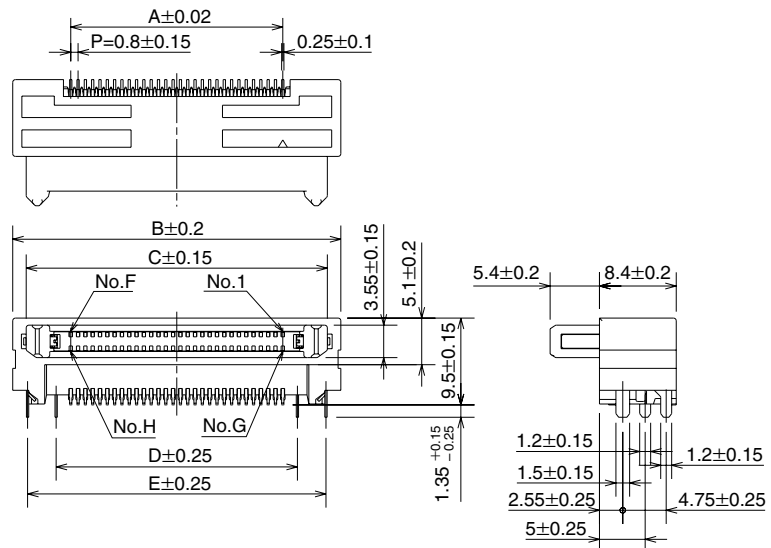

All dimensions in mm

Part Number	HRS No.	A	B	C	D	E	F	G	H(pos.)
★ FX18-40P-0.8SH	CL579-0002-5	15.2	27.9	24.95	18.4	24.65	20	21	40
★ FX18-60P-0.8SH	CL579-0003-8	23.2	35.9	32.95	26.4	32.65	30	31	60
FX18-80P-0.8SH	—	31.2	43.9	40.95	34.4	40.65	40	41	80
FX18-100P-0.8SH	—	39.2	51.9	48.95	42.4	48.65	50	51	100
★ FX18-120P-0.8SH	CL579-0006-6	47.2	59.9	56.95	50.4	56.65	60	61	120
FX18-140P-0.8SH	—	55.2	67.9	64.95	58.4	64.65	70	71	140

★ indicates "available". No marking, "under development"

## ■Straight Header

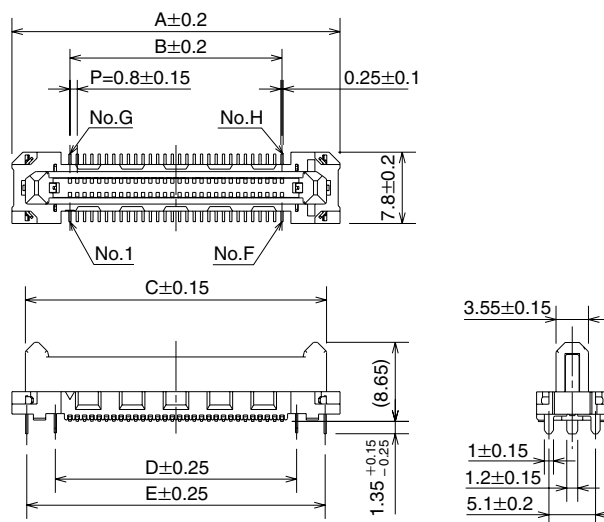

All dimensions in mm

Part Number	HRS No.	A	B	C	D	E	F	G	H(pos.)
★ FX18-40P-0.8SV	CL579-0016-0	27.9	15.2	24.95	18.4	24.65	20	21	40
★ FX18-60P-0.8SV	CL579-0017-2	35.9	23.2	32.95	26.4	32.65	30	31	60
★ FX18-80P-0.8SV	CL579-0018-5	43.9	31.2	40.95	34.4	40.65	40	41	80
FX18-100P-0.8SV	—	51.9	39.2	48.95	42.4	48.65	50	51	100
★ FX18-120P-0.8SV	CL579-0020-7	59.9	47.2	56.95	50.4	56.65	60	61	120
FX18-140P-0.8SV	—	67.9	55.2	64.95	58.4	64.65	70	71	140

★ indicates "available". No marking, "under development"

## Recommended Land Pattern Dimension of PCB

(PCB thickness:  $t=1.6\text{mm}$  / Metal mask thickness:  $t=0.12\text{mm}$ )

### Right Angle Receptacle / Right Angle Header

All dimensions in mm

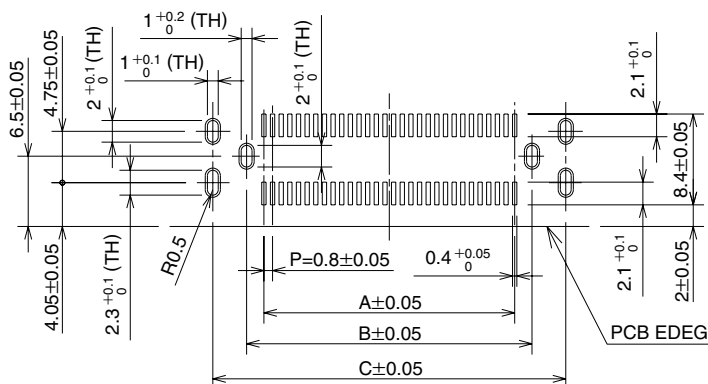

Part Number	A	B	C
FX18-40S-0.8SH	15.2	18.4	24.65
FX18-40P-0.8SH			
FX18-60S-0.8SH	23.2	26.4	32.65
FX18-60P-0.8SH			
FX18-80S-0.8SH	31.2	34.4	40.65
FX18-80P-0.8SH			
FX18-100S-0.8SH	39.2	42.4	48.65
FX18-100P-0.8SH			
FX18-120S-0.8SH	47.2	50.4	56.65
FX18-120P-0.8SH			
FX18-140S-0.8SH	55.2	58.4	64.65
FX18-140P-0.8SH			

### Straight Header

All dimensions in mm

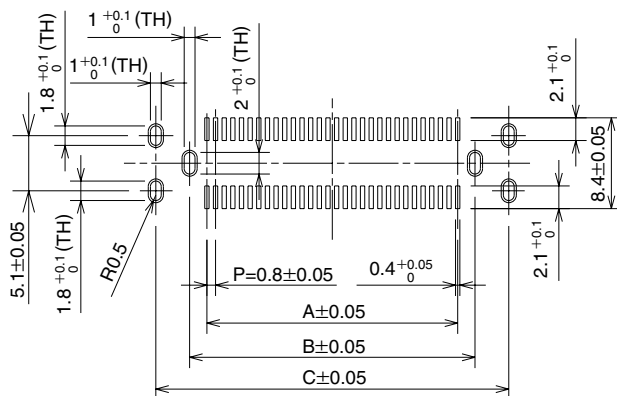

Part Number	A	B	C
FX18-40P-0.8SV	15.2	18.4	24.65
FX18-60P-0.8SV	23.2	26.4	32.65
FX18-80P-0.8SV	31.2	34.4	40.65
FX18-100P-0.8SV	39.2	42.4	48.65
FX18-120P-0.8SV	47.2	50.4	56.65
FX18-140P-0.8SV	55.2	58.4	64.65

## ■Packing specification

### ●Right Angle Receptacle / Right Angle Header

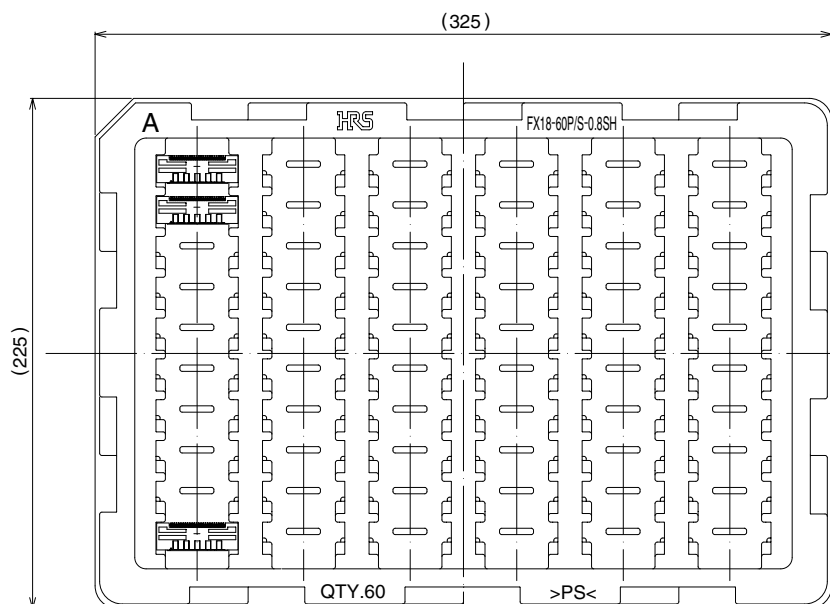

Part Number	Quantity
FX18-40S-0.8SH	70
FX18-40P-0.8SH	
FX18-60S-0.8SH	60
FX18-60P-0.8SH	
FX18-80S-0.8SH	50
FX18-80P-0.8SH	
FX18-100S-0.8SH	40
FX18-100P-0.8SH	
FX18-120S-0.8SH	40
FX18-120P-0.8SH	
FX18-140S-0.8SH	30
FX18-140P-0.8SH	

### ●Straight Header

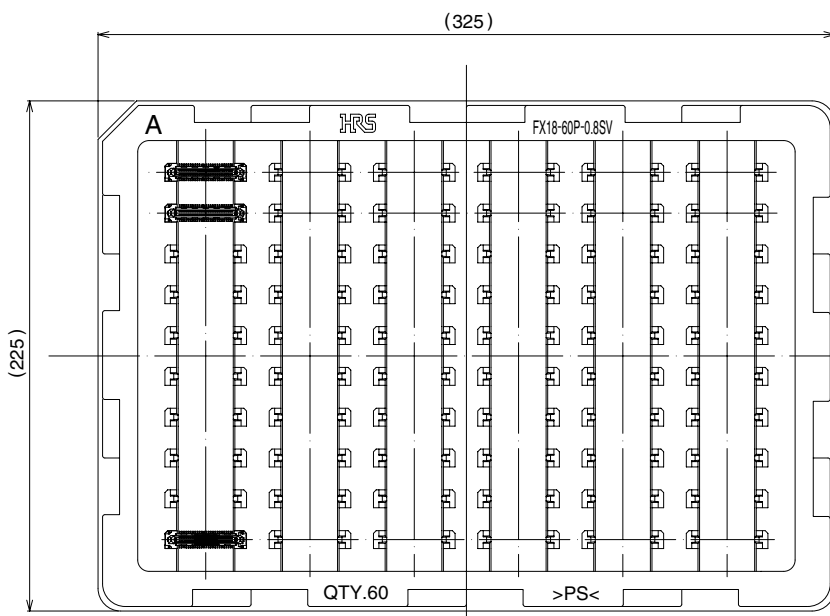

Part Number	Quantity
FX18-40P-0.8SV	70
FX18-60P-0.8SV	60
FX18-80P-0.8SV	50
FX18-100P-0.8SV	40
FX18-120P-0.8SV	40
FX18-140P-0.8SV	30

## ■ Mounting Temperature Profile (Reference)

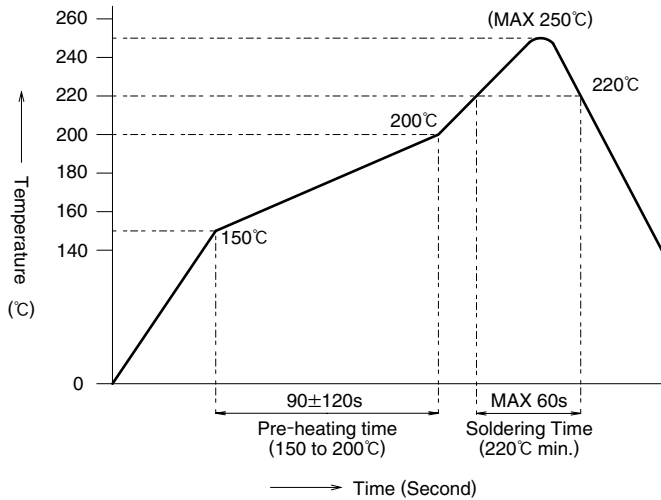

### HRS test conditions

Test board dimension	: 110×50×1.6mm
material	: Glass epoxy
Solder method	: Reflow
Solder composition	: Paste Sn-3Ag-0.5Cu
Metal mask	: 0.12mm thick
Reflow cycle	: 2 cycle

The temperature profile is based on the above conditions. In individual applications the actual temperature may vary, depending on solder paste type, Volume/thickness and board size/thickness. Consult your solder paste and equipment manufacturer for specific recommendations.

## ■ Cleaning recommendations

### ● Organic solvent cleaning

Solvent Type	Room temperature cleaning	Heated cleaning
IPA ( Isopropyl alcohol)	YES	YES
HCFC ( Hydrochlorofluorocarbon )	YES	YES

### ● Water based cleaning

When using water based cleaning agents (e.g., terpene, alkali saponifiers), select the cleaning agent based on the documentation issued by the various manufacturers of cleaning agents which describes it's affects on metals, platings and plastics. Remove any moisture after cleaning.

Residual flux or cleaning agents in the contact areas may affect electrical performance.

## ■ Connector Precautions

### ● Allowable Clearance between the Mated Pair

Recommend the allowable clearance at mating including angled insertion to be Max.1mm.

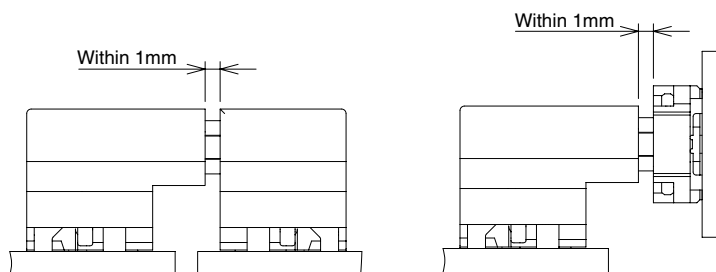

### ● PCB Fixture

PCB and chassis can not be stabilized only by the connector.

Fixture to stabilize the PCB is necessary.

When fitting using a rotary insertion plug, please ensure you refer to the Rotary Insertion Guideline (TADC 4-210630)