

USE HANDBOOK

For ZIF Type Connectors

**(Flexible Printed Circuit and
Flexible Flat Cable Connections)**

Flip-Lock Rotating One Touch™ Actuator

**Information contained herein is proprietary to
Hirose Electric and should not be copied or
distributed without proper authorization and
is subject to update/change without notice.**



Contents

1. Introduction

2. Parts Description

3. Common Precautions and recommendations

4. Connector Operating Instructions, precautions and recommendations

4.1 FH12 Series Bottom Contact Point Type

4.2 FH12 Series Top Contact Point Type

4.3 FH12 Series Vertical Mounting Type

4.4 FH16 Series

4.5 FH17 Series

4.6 FH18 Series

4.7 FH19 Series

4.8 FH23 Series

1. Introduction

Flip-Lock rotating One-Touch Actuator is the Zero Insertion Force connection method of FH Series connectors to FPC and FFC. Hirose Electric is the first company, which developed this revolutionary connection system, solving the common problems associated with non-ZIF and sliding ZIF connection failures. FH Series connectors provide ease of FPC/FFC insertion/removal while assuring high reliability mechanical and electrical connection. The connectors are designed for high density packaging applications. As such, they are small and thin. Following the recommendations given in this Handbook will avoid damage to connectors and assure correct mounting and operation.

2. Parts Description

2.1 Bottom Contact Point Type

(FPC/FFC is inserted horizontally with contact PADS facing down, toward the mounting surface)

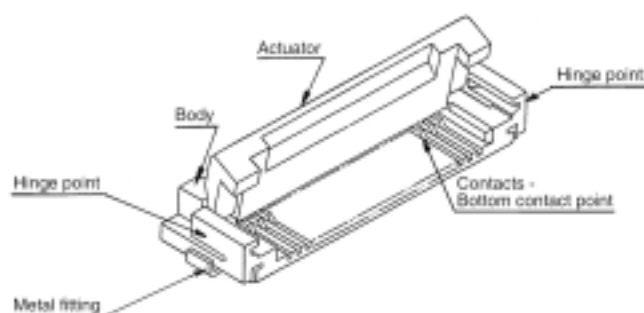

2.2 Top Contact Point Type

(FPC/FFC is inserted horizontally with contact PADS facing upward, away from the mounting surface.)

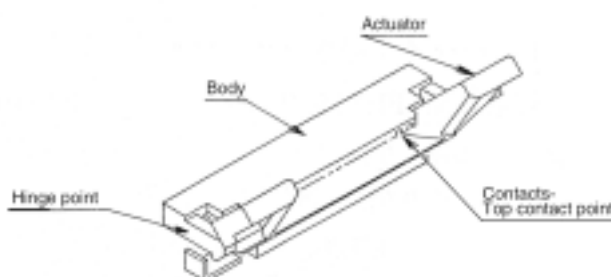

2.3 Parts Description of the Vertical Mounting Type

(The FPC/FFC is inserted vertically with respect to the board.)

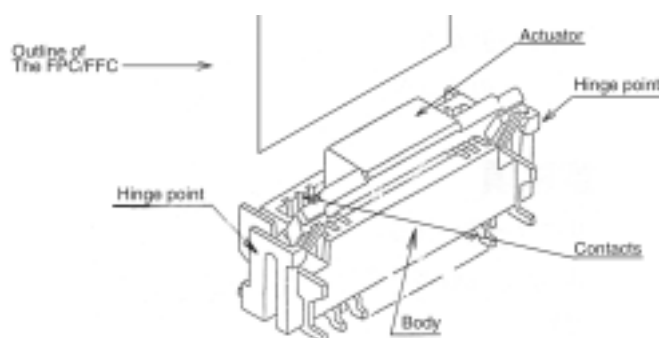

3. Common Precautions and recommendations

3.1 Precautions at the time of installation on PCB

3.1.1 Temperature Profile and Metal Mask Thickness

HRS catalog and literature clearly specifies recommended temperature and metal mask thickness when mounting the connector on PCB.

Size of the PCB and the volume of the reflow layer may influence the final results.

3.1.2 Cleaning recommendations

Organic Solvent Cleaning

Solvent type	Normal temperature Cleaning	Heated Cleaning
IPA (Isopropyl alcohol)	○	○
HCFC (Hydro chlorofluorocarbon)	○	○

Water Based Cleaning

When using aqueous type cleaning agents (e.g., terpene, and alkali saponifiers), select the cleaning agent based on the documentation issued by the various manufactures of cleaning agents, which describes its effects on metals and resins.

It is critical that the connectors be completely dry, without any moisture residue left.

Cleaning Precautions

Residual flux or cleaning agent on the connectors, when washing with organic solvents or aqueous type cleaners, can cause deterioration of electrical performance. It is important that thorough cleaning has been performed.

3.1.3 Pick and Place Areas

All connectors are packaged to allow placement with automatic placement equipment. Catalogues and specific literature clearly define surfaces for the pick-and-place nozzles.

3.1.4 Manual Soldering Precautions

(1) Do not apply excessive heat or touch anything other than the connector terminals with the soldering tip.

Recommended manual soldering conditions: 350 +/- 5°C, for max. of 3 seconds.

(2) Control the amount of soldering and flux compounds.

Excessive solder on the contacts may overflow to the contact area or the rotating actuator affecting electrical or mechanical performance. Too much of the solder compound on the metal fittings may affect free rotating of the actuator and cause damage to the connector. These conditions are shown on figure no. 1 and 2 below.

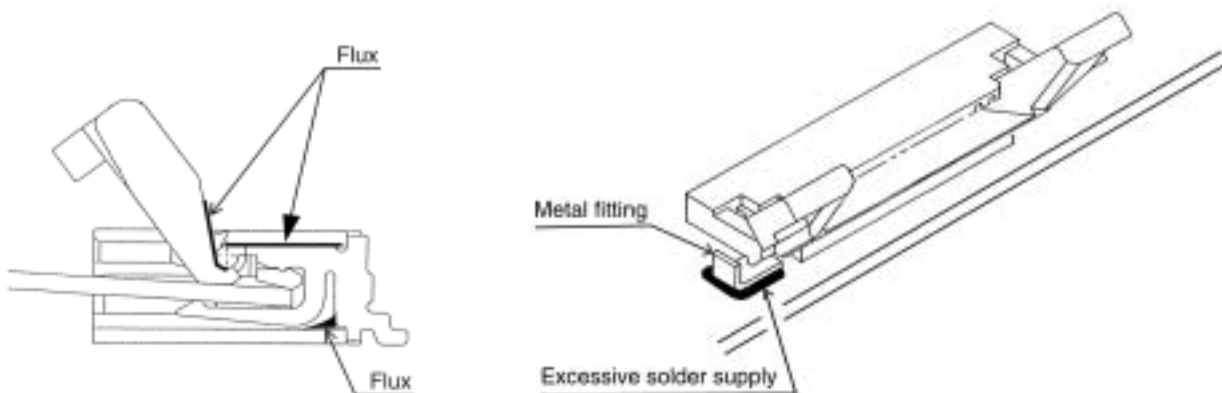

3.2 Precautions After Connector is MOUNTED on the PCB

When storing or transporting the board with connector installed it is critical that the actuator is closed and the connector is NOT subject to any damage caused by other board or component.

Do not place board directly on mounted connectors.

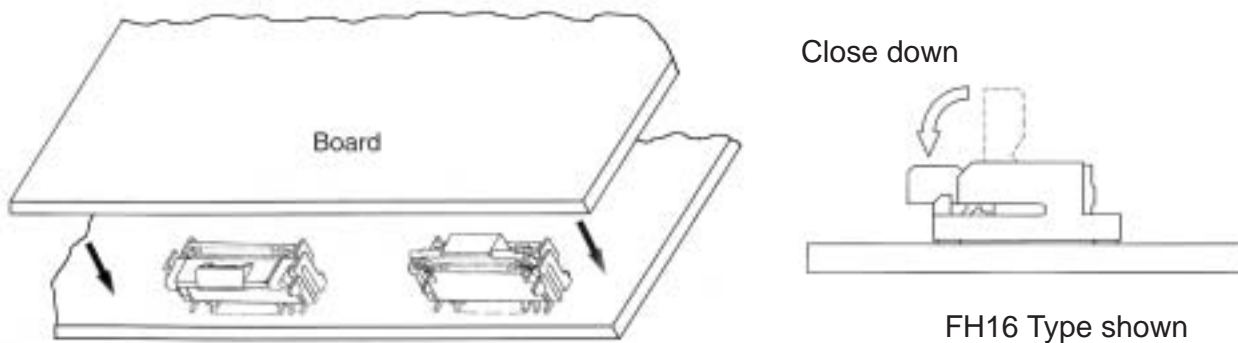

3.3 Precautions After FPC/FFC is inserted and actuator closed

Application of excessive force to the inserted FPC/FFC may cause damage to connector and may affect the reliability of electrical connection. If specific application requires continuous or repeated pull or bend of the inserted FPC/FFC, assure that the forces are NOT transmitted directly to the connector.

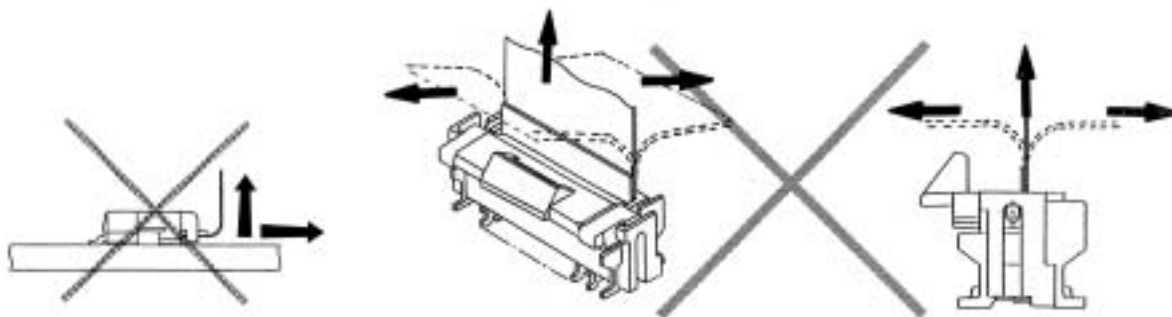

4. Connector Operating Instructions, precautions and recommendations

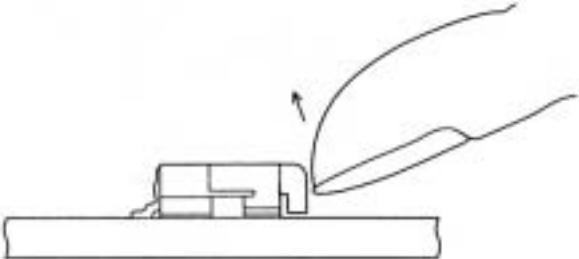
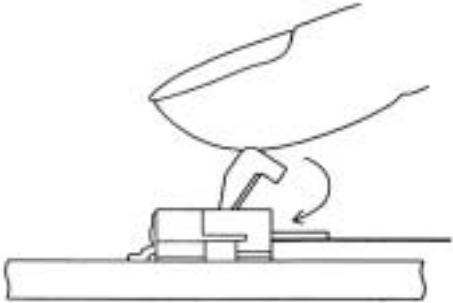
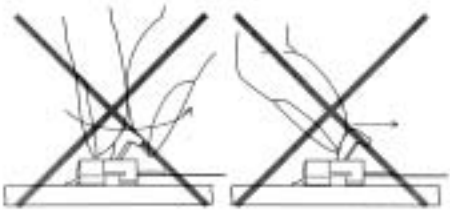
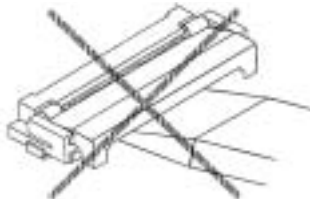
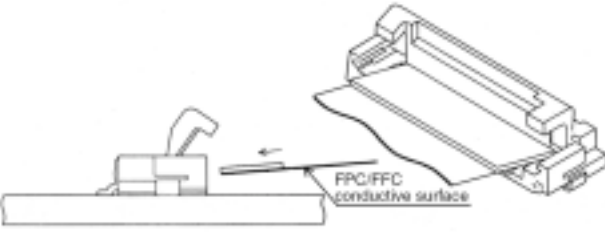
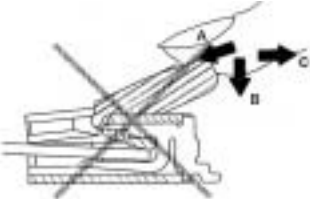

4.1 FH12 Series Bottom contact point Type

Operation	Precautions
<p>1. FPC/FFC Termination procedure. Connector installed on the board.</p> <p>1) Lift up the actuator. Use thumb or index finger.</p>  <p>2) Rotate down the actuator until firmly closed. It is critical that the inserted FPC/FFC is not moved and remains fully inserted. Should the FPC/FFC be moved, open the actuator and repeat the process, starting with Step 1 above.</p> 	<p>1) Avoid grasping the actuator with two fingers or lifting the lever with fingernail.</p>  <p>2) DO NOT use screwdriver or any other tool to open the actuator.</p>  <p>3) Fully insert the FPC/FFC parallel to mounting surface, with the exposed conductive traces facing down.</p>  <p>4) Do NOT force actuator in direction of A, B or C.</p> 

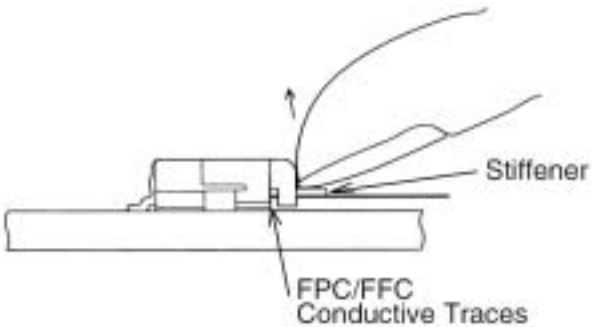
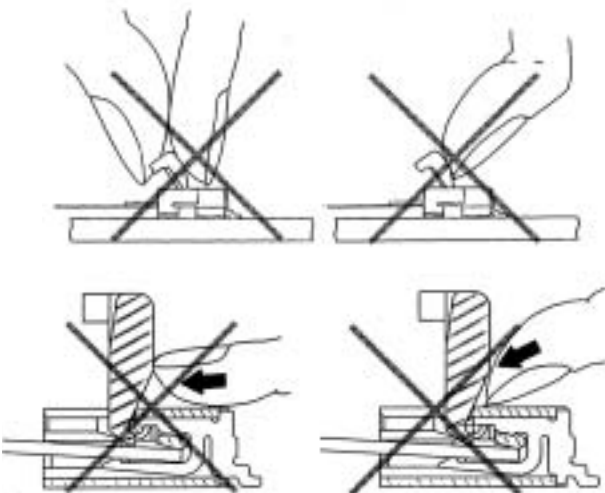



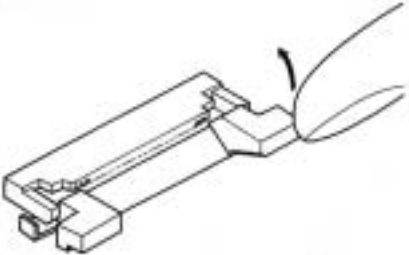
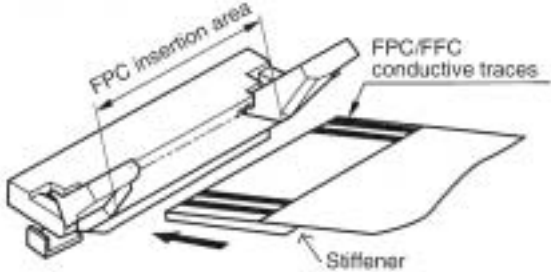
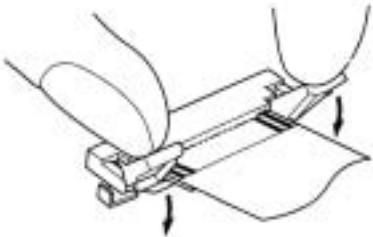
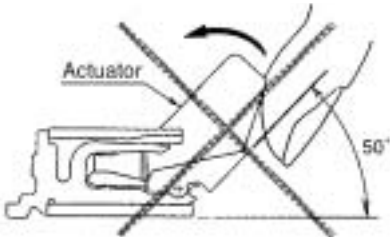
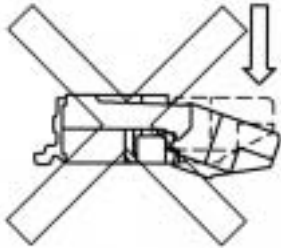

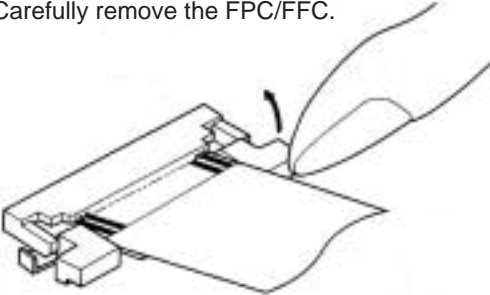
4.1 FH12 Series Bottom contact point Type

Operation	Precautions
<p data-bbox="147 389 553 484">2. FPC/FFC removal. 1) Lift up the actuator. 2) Carefully remove the FPC/FFC.</p> 	<p data-bbox="846 389 1471 449">5) Do NOT push/pull actuator. Any damage to actuator will require replacement of the entire connector.</p> 

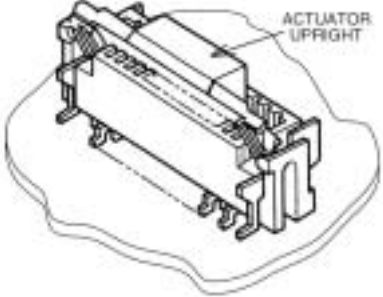
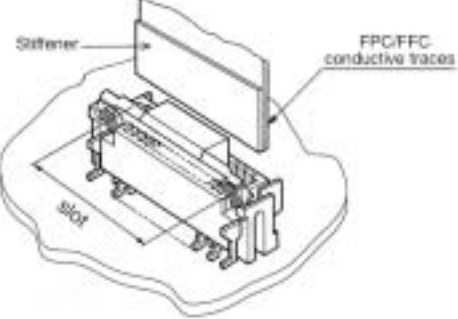
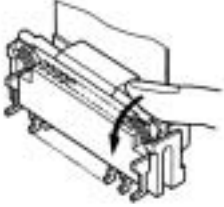

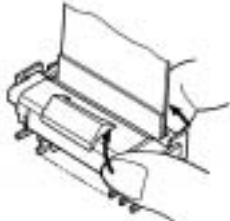
4.2 FH12 Series Top contact point Type

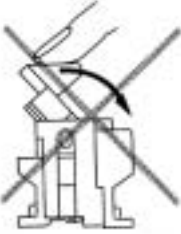
Operation	Precautions
<p>1. FPC/FFC Termination procedure. Connector installed on the board.</p> <p>1) Lift up the actuator. Use thumb or index finger.</p>  <p>2) Fully insert the FPC/FFC parallel to mounting surface, with the exposed conductive traces facing up.</p>  <p>3) Rotate down the actuator until firmly closed. It is critical that the inserted FPC/FFC is not moved and remains fully inserted. Should the FPC/FFC be moved, open the actuator (per Step 2 above) and repeat the process, starting with Step 1 above.</p> 	<p>1) Avoid forcing the actuator up or down without the FPC/FFC inserted.</p>   <p>2) When closing down the actuator apply equal pressure to both sides of the actuator.</p> 
<p>2. FPC/FFC removal.</p> <p>1) Lift up the actuator.</p> <p>2) Carefully remove the FPC/FFC.</p> 	

4.3 FH12 Series - Vertical FPC/FFC insertion

Operation	Precautions
<p>1. FPC/FFC Termination procedure. Connector installed on the board.</p> <p>1) Verify that the actuator is positioned upright. If the actuator has rotated to the side, carefully rotate it upright.</p>  <p>2) Insert the FPC/FFC vertically in the connector slot assuring that the conductive traces of the FPC/FFC are facing away from the actuator.</p>  <p>3) Press down the actuator in the direction shown.</p>   <p>2. FPC/FFC removal.</p> <p>Rotate the actuator upward and withdraw the FPC/FFC.</p>  	<p>1) Avoid forcing the actuator up or down without the FPC/FFC inserted.</p>  

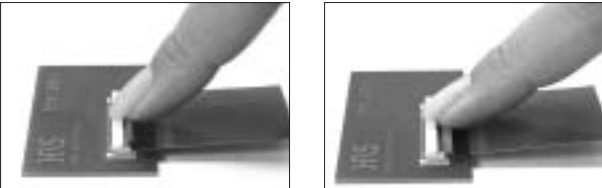

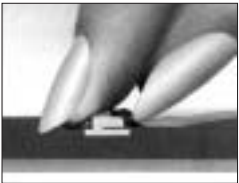
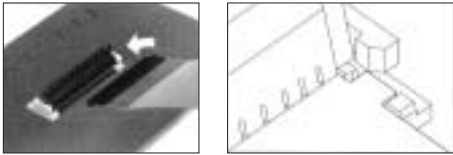
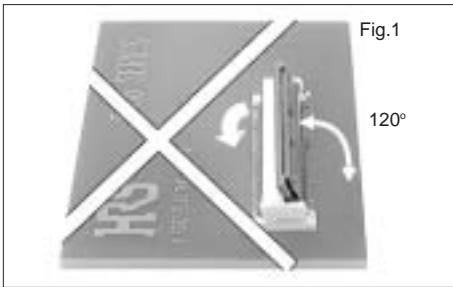
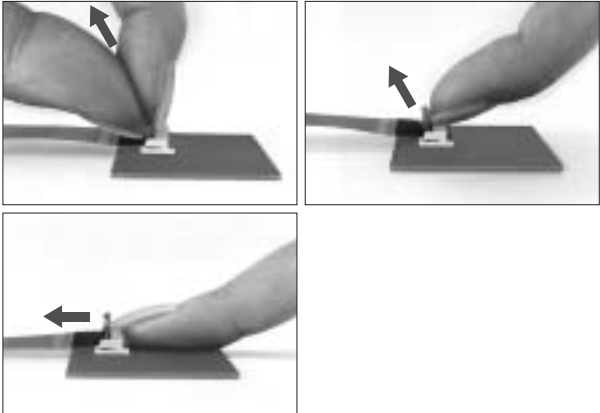
4.4 FH16 Series

Operation	Precautions
<p>1. FPC Termination procedure. Connector installed on the board.</p> <p>1) Remove and dispose the pick-and-place insert.</p>  <p>2) Rotate down the actuator until firmly closed. It is critical that the inserted FPC is not moved and remains fully inserted. Should the FPC be moved, open the actuator and repeat the process, starting with Step 1 above.</p>   <p>2. FPC removal.</p> <p>1) Lift up the actuator.</p> <p>2) Carefully remove FPC.</p> 	<p>1) Fully insert the FPC parallel to mounting surface, with the exposed conductive traces facing down.</p>  <p>2) The connector will assure reliable performance when the actuator is open to 120° maximum (see fig.1) Do not exceed this angle, as this may cause permanent damage to the connector!</p>  <p>3) Do NOT push/pull actuator. Any damage to actuator will require replacement of the entire connector.</p> 

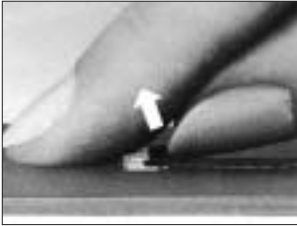
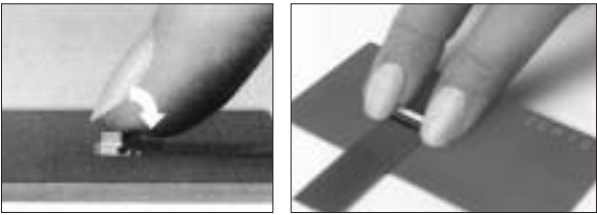
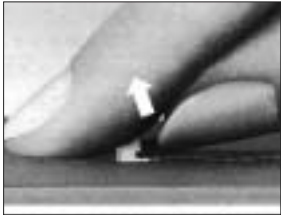
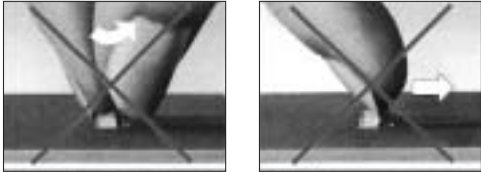
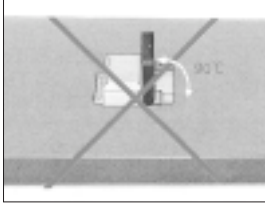
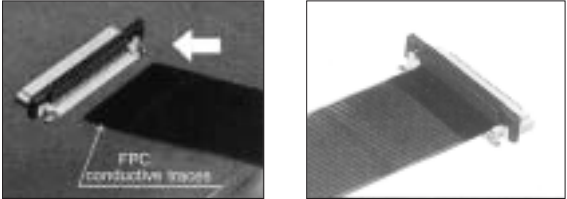

4.5 FH17 Series

Operation	Precautions
<p>1. FPC Termination procedure. Connector installed on the board.</p> <p>1) Lift up the actuator. Use thumb or index finger.</p>  <p>2) Rotate down the actuator until firmly closed. It is critical that the inserted FPC is not moved and remains fully inserted. Should the FPC be moved, open the actuator and repeat the process, starting with Step 1 above.</p>  <p>2. FPC removal.</p> <p>1) Lift up the actuator.</p> <p>2) Carefully remove the FPC.</p> 	<p>1) Do not apply excessive force or use any type of tool to operate the actuator.</p>  <p>2) The connector will assure reliable performance when the actuator is open to 90° maximum (see fig.1) Do not exceed this angle, as this may cause permanent damage to the connector!</p>  <p>Fig.1</p> <p>3) Assure that the FPC is fully inserted parallel to mounting surface, with the exposed conductive traces facing down.</p> 

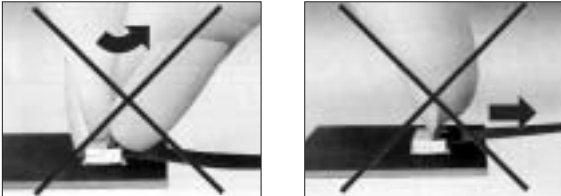
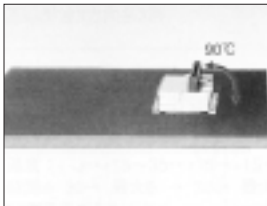
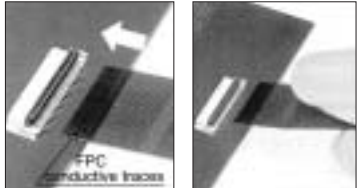
4.6 FH18 Series

Operation	Precautions
<p>1. FPC Termination procedure. Connector installed on the board.</p> <p>1) Lift up the actuator. Use thumb or index finger.</p>  <p>2) Rotate down the actuator until firmly closed. It is critical that the inserted FPC is not moved and remains fully inserted. Should the FPC be moved, open the actuator and repeat the process, starting with Step 1 above.</p>  <p>2. FPC removal.</p> <p>1) Lift up the actuator.</p> <p>2) Carefully remove the FPC.</p> 	<p>1) Do not apply excessive force or use any type of tool to operate the actuator.</p>  <p>2) The connector will assure reliable performance when the actuator is open to 90° maximum (see fig.1) Do not exceed this angle, as this may cause permanent damage to the connector!</p>  <p>3) Assure that the FPC is fully inserted parallel to mounting surface, with the exposed conductive traces facing down.</p> 

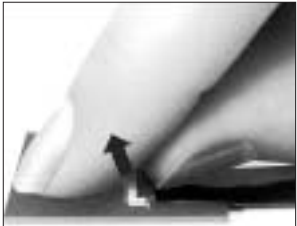
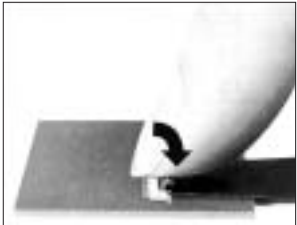
4.7 FH19 Series

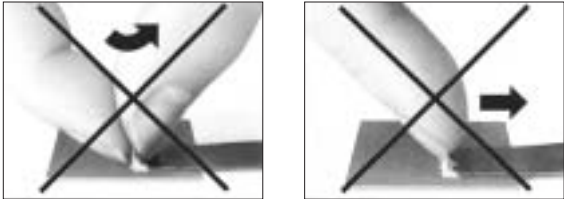
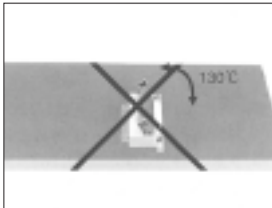
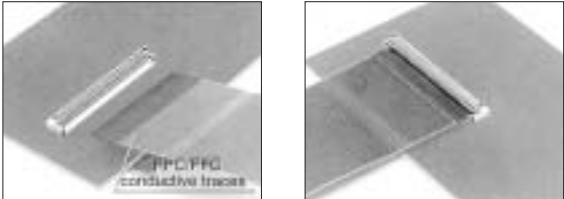
Operation	Precautions
<p>1. FPC/FFC Termination procedure. Connector installed on the board.</p> <p>1) Lift up the actuator. Use thumb or index finger.</p>  <p>2) Rotate down the actuator until firmly closed. It is critical that the inserted FPC/FFC is not moved and remains fully inserted. Should the FPC/FFC be moved, open the actuator and repeat the process, starting with Step 1 above.</p>  <p>2. FPC/FFC removal.</p> <p>1) Lift up the actuator.</p> <p>2) Carefully remove the FPC/FFC.</p> 	<p>1) Do not apply excessive force or use ant type of tool to operate the actuator.</p>  <p>2) The connector will assure reliable performance when the actuator is open to 130° maximum (see fig.1) Do not exceed this angle, as this may cause permanent damage to the connector!</p>  <p>3) Assure that the FPC/FFC is fully inserted parallel to mounting surface, with the exposed conductive traces facing down.</p> 

4.8 FH23 Series

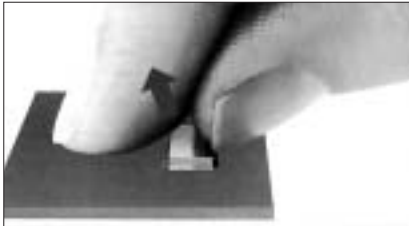
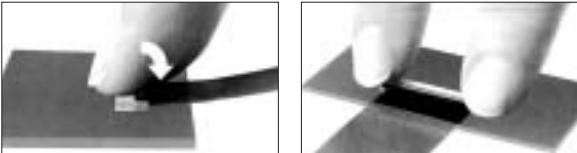
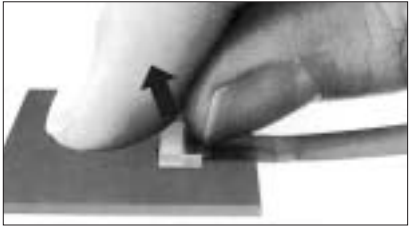
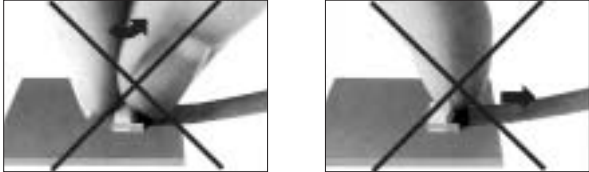
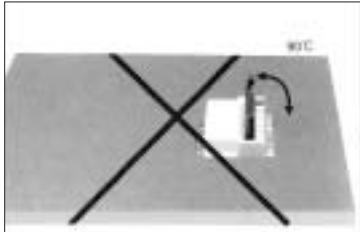
Operation	Precautions
<p>1. FPC Termination procedure. Connector installed on the board.</p> <p>1) Lift up the actuator. Use thumb or index finger.</p>  <p>2) Rotate down the actuator until firmly closed. It is critical that the inserted FPC is not moved and remains fully inserted. Should the FPC be moved, open the actuator and repeat the process, starting with Step 1 above.</p>  <p>2. FPC removal.</p> <p>1) Lift up the actuator.</p> <p>2) Carefully remove the FPC.</p> 	<p>1) Do not apply excessive force or use any type of tool to operate the actuator.</p>  <p>2) The connector will assure reliable performance when the actuator is open to 90° maximum (see fig.1) Do not exceed this angle, as this may cause permanent damage to the connector!</p>  <p>3) Assure that the FPC is fully inserted parallel to mounting surface, with the exposed conductive traces facing down.</p> 