

# Programmable Attenuators

## P-AT Series



### ■ Features

#### 1. Used for frequencies from DC to 32GHz (max.)

Input/output couplings utilizes Hirose's HE\* connector, which is combination of the internal attenuation elements, provides the required attenuation characteristic.

#### 2. Self-disconnecting

The drive current will automatically switch off after setting the attenuation.

#### 3. Automatic return

In the event of sudden shock the attenuation will quickly return to the pre-set level.

### ■ Applications

Wide variety of measuring instruments and other devices requiring control of high frequency transmission lines.

- \* HE connector will mate with K type connectors
- \* K connector is a trademark of Anritsu Co.

### ■ Product Specifications

Ratings	Frequency range	DC~8GHz(P-AT-6,AP-AT-7) DC~26.5GHz(P-AT-8) DC~32GHz(P-AT-9)	Operating temperate range Operating relative humidity	-10°C to +75°C(No freezing) 95% Max.
---------	-----------------	---	--	---

Characteristic	Requirements	Conditions
1.Vibration	No electrical discontinuity of 1 μs or more No damage, cracks, or parts dislocation	Frequency of 10 to 55 Hz, overall amplitude of 1.5 mm for 2 hours in each of 3 directions
2.Shock		Acceleration of 98 m/s <sup>2</sup> , sine half-wave waveform, 3 cycles in each of the 3 axis
3.Temperature cycle	No damage, cracks, or parts dislocation	Temperature : -20°C → +15°C to +35°C → +85°C → +15°C to +35°C Time : 30 → 2 to 3 → 30 → 2 to 3 (Minutes) 100 cycles

●The test method conforms to MIL-STD-202.

### ■ Materials and Finishes

Component	Material	Finish
Body	Aluminum	Conductive alumite
Coupling connector body	Stainless steel	Passivated
Female contact	Beryllium Copper	Gold plating

### ■ Ordering Information

**P-AT - 6 ( 8 - 70 ) A (40)**

① Series Name
② Suffix
③ Maximum frequency (GHz)
④ Maximum attenuation (dB)
⑤ Revised
⑥ (40): RoHS Compliant

## Specifications

Part No.	Frequency Range (GHz)	V.S.W.R. (Max)	Attenuation (dB)	Attenuation Accuracy (dB)				Insertion Loss (dB) (Max)	Impedance (Ω)	Power (W)	Switching Volt (DC V)	Switching Current (Each Section) (mA)	Switching Time (ms)(Max)	Operating Life	Connectors	Weight (g)	RoHS
				5dB	10dB	20dB	40dB										
P-AT-6(8-70)A(40)	DC~8	1.35	0~70 (10dB Step)	—	±0.5	±0.6	±1	1.5	50	1(CW)	24	120+200 ×3 section	20	2×10 <sup>6</sup>	HE-J · J	250	YES
P-AT-6(8-65)A(40)	DC~8	1.35	0~70 (10dB Step)	±0.5	—	±0.6	±1	1.5	50	1(CW)	24	120+200 ×3 section	20	2×10 <sup>6</sup>	HE-J · J	250	
P-AT-7(8-75)A(40)	DC~8	1.35	0~75 (5dB Step)	±0.5	±0.5	±0.6	±1	1.5	50	1(CW)	24	160+200 ×4 section	20	2×10 <sup>6</sup>	HE-J · J	300	
P-AT-7(14-75)A(40)	DC~14	1.35 (DC~8GHz)	0~75 (5dB Step)	Ref table 1				0.55+ 0.12×f (GHz)	50	1(CW)	24	160+200 ×4 section	20	2×10 <sup>6</sup>	HRM-J · J	300	
		1.5 (8~14GHz)															
P-AT-8(26.5-70)A(40)	DC~26.5	1.4 (DC~12GHz)	0~70 (10dB Step)	Ref table 2				0.55+ 0.06×f (GHz)	50	1(CW)	24	120+200 ×3 section	20	2×10 <sup>6</sup>	HE-J · J	240	
		1.7 (12~26.5GHz)															
P-AT-9(32-75)A(40)	DC~32	1.4 (DC~8GHz)	0~75 (5dB Step)	Ref table 3				0.55+ 0.085×f (GHz)	50	1(CW)	24	160+200 ×4 section	20	2×10 <sup>6</sup>	HE-J · J	280	
		1.45 (8~12GHz)															
		1.7 (12~26.5GHz)															
		2.0 (26.5~32GHz)															

Table 1

Frequency Range (GHz)	Attenuation Accuracy(dB)							
	5,10	15,20	25,30	35,40	45,50	55,60	65,70	75
DC~8	±0.4	±0.5	±0.6	±0.8	±1.0	±1.2	±1.4	±1.6
8~14	±0.8	±1.2	±1.2	±1.4	±1.4	±1.6	±1.8	±2.5

Table 2

Frequency Range (GHz)	Attenuation Accuracy(dB)						
	10dB	20dB	30dB	40dB	50dB	60dB	70dB
DC~8	±0.3	±0.5	±0.6	±0.7	±0.8	±1.0	±1.1
8~12	±0.4	±0.5	±0.7	±0.9	±1.0	±1.3	±1.5
12~20	±0.5	±0.6	±0.8	±1.1	±1.2	±1.4	±1.7
20~26.5	±0.7	±0.8	±1.0	±1.5	±1.6	±1.9	±2.3

Table 3

Frequency Range (GHz)	Attenuation Accuracy(dB)							
	5,10	15,20	25,30	35,40	45,50	55,60	65,70	75
DC~8	±0.3	±0.5	±0.6	±0.7	±0.8	±1.0	±1.1	±1.2
8~12	±0.4	±0.5	±0.7	±0.9	±1.0	±1.3	±1.5	±1.7
12~20	±0.5	±0.6	±0.8	±1.1	±1.2	±1.4	±1.7	±1.9
20~26.5	±0.7	±0.8	±1.0	±1.5	±1.6	±1.9	±2.3	±2.5
26.5~32	±0.9	±1.0	±1.2	±1.7	±1.9	±2.3	±2.6	±2.8

## Typical Data

P-AT-9(32-75)A(40)

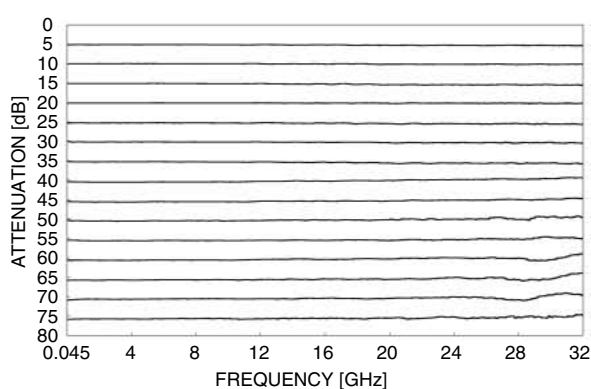
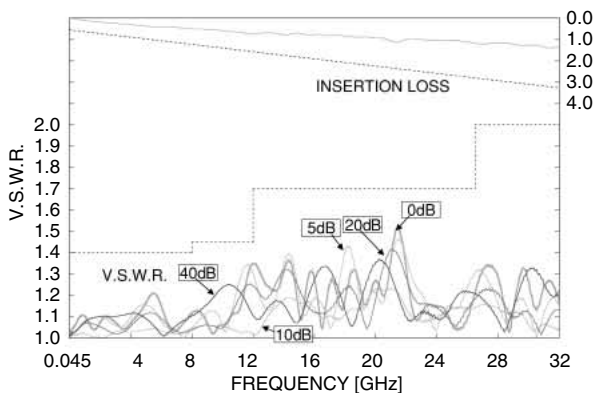

P-AT Series Programmable Attenuators

## External Dimensions

P-AT-6(8-70)A(40)

P-AT-6(8-65)A(40)

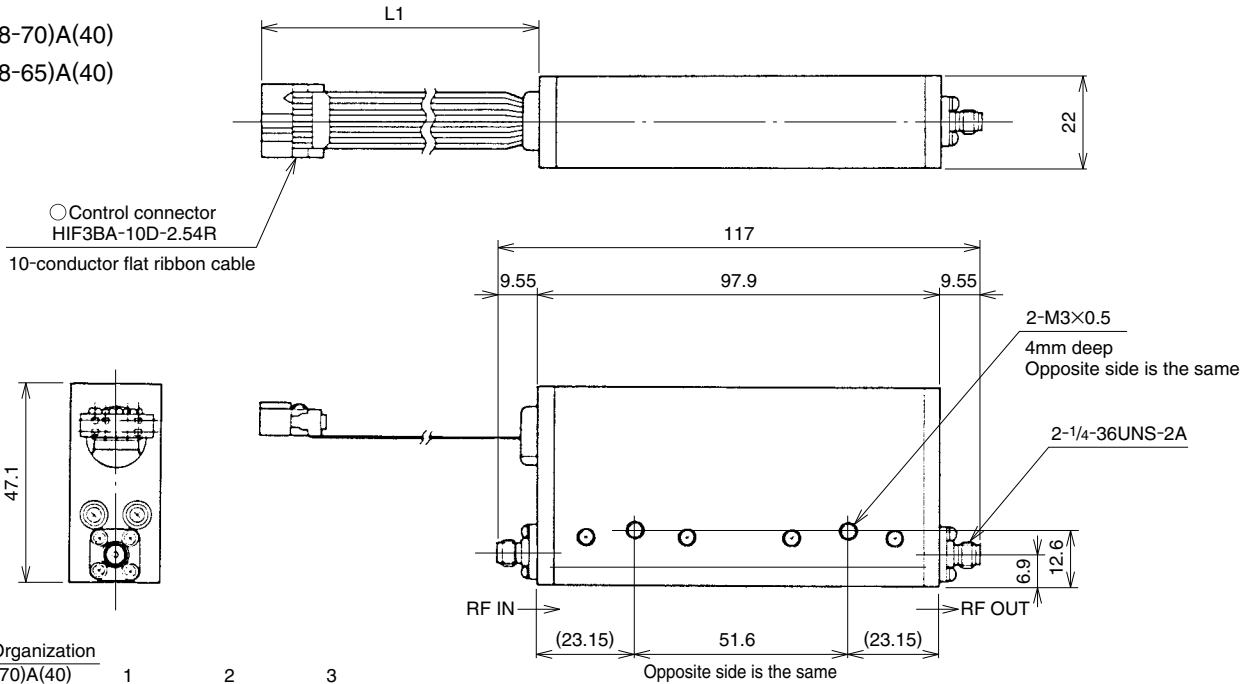

○Circuit Organization

P-AT-6(8-70)A(40)

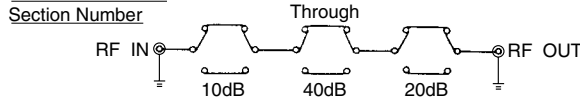

P-AT-6(8-65)A(40)

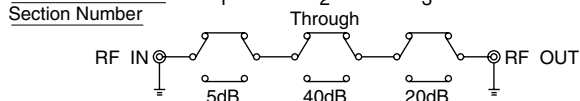

Part No.	L1 Dimension
P-AT-6(8-70)A(40)	340
P-AT-6(8-65)A(40)	140

P-AT-7(8-75)A(40)

P-AT-7(14-75)A(40)

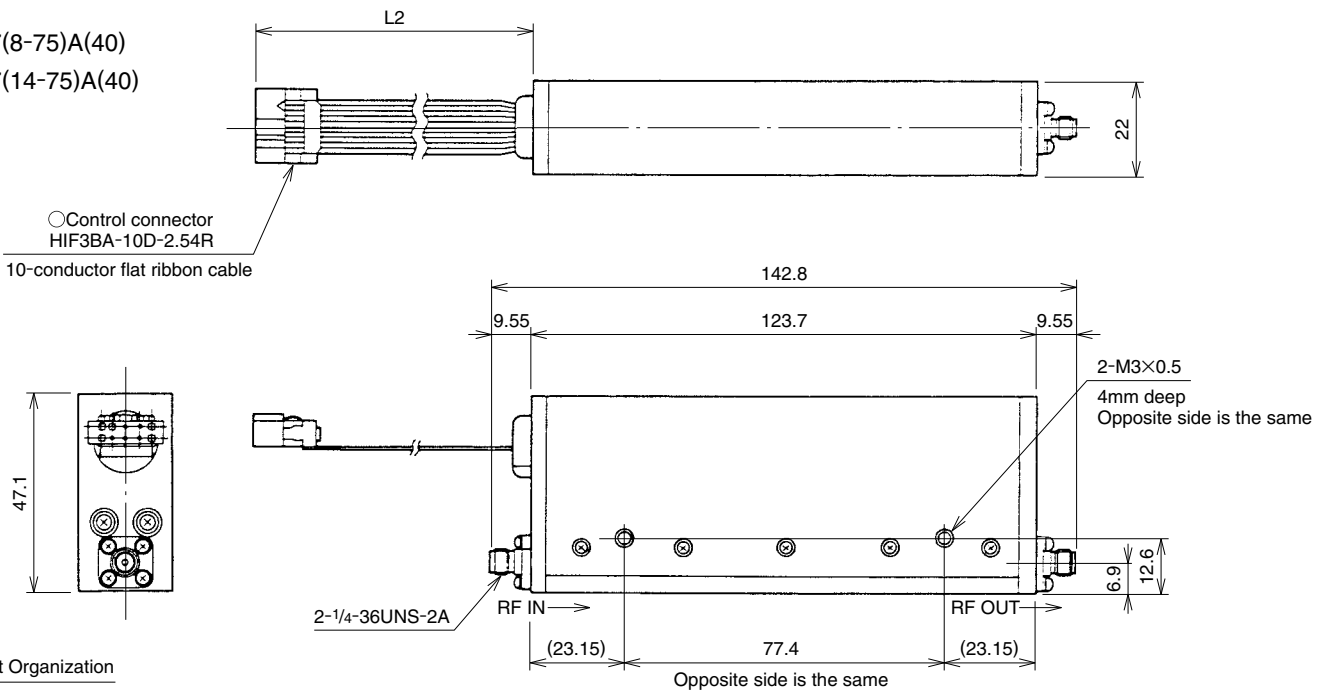

○Circuit Organization

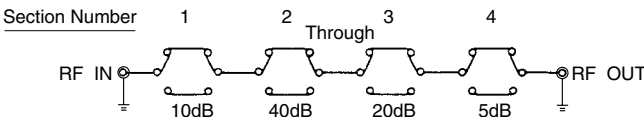

Part No.	L2 Dimension
P-AT-7(8-75)A(40)	250
P-AT-7(14-75)A(40)	300

## External Dimensions

P-AT-8(26.5-70)A(40)

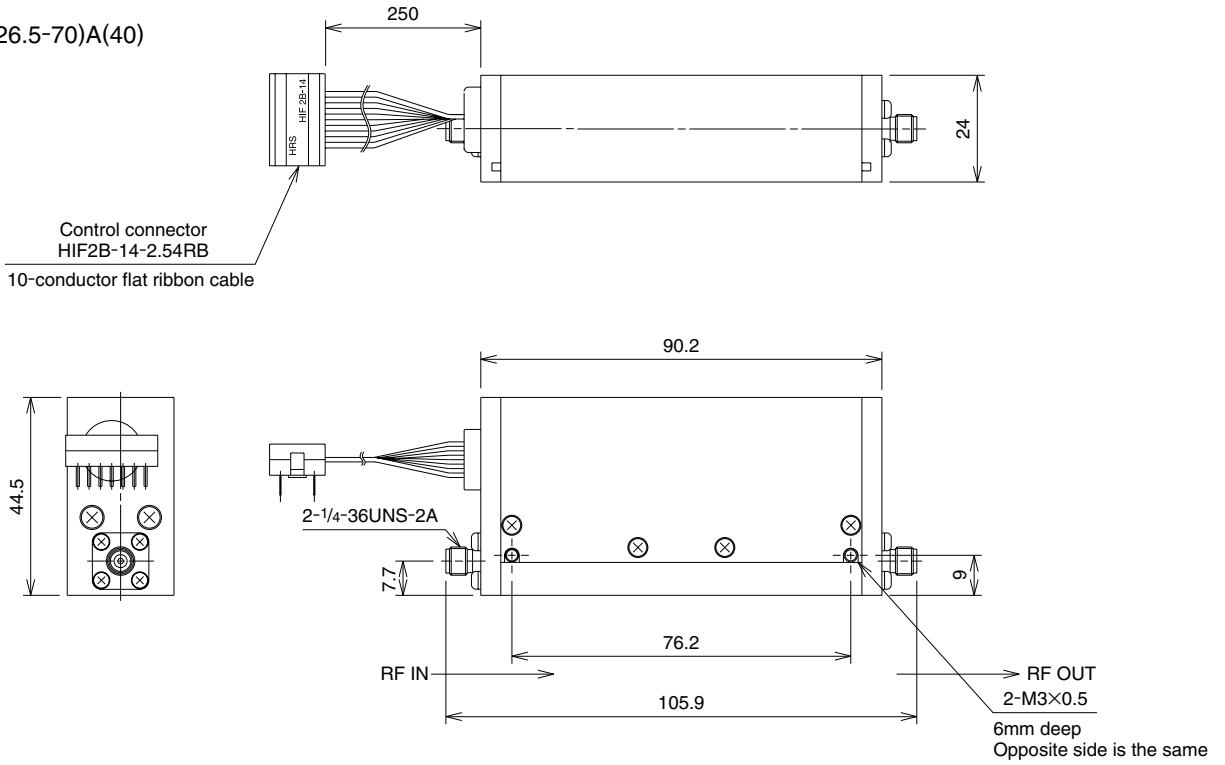

○Circuit Organization

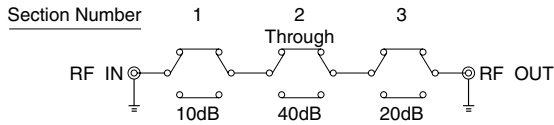

P-AT-9(32-75)A(40)

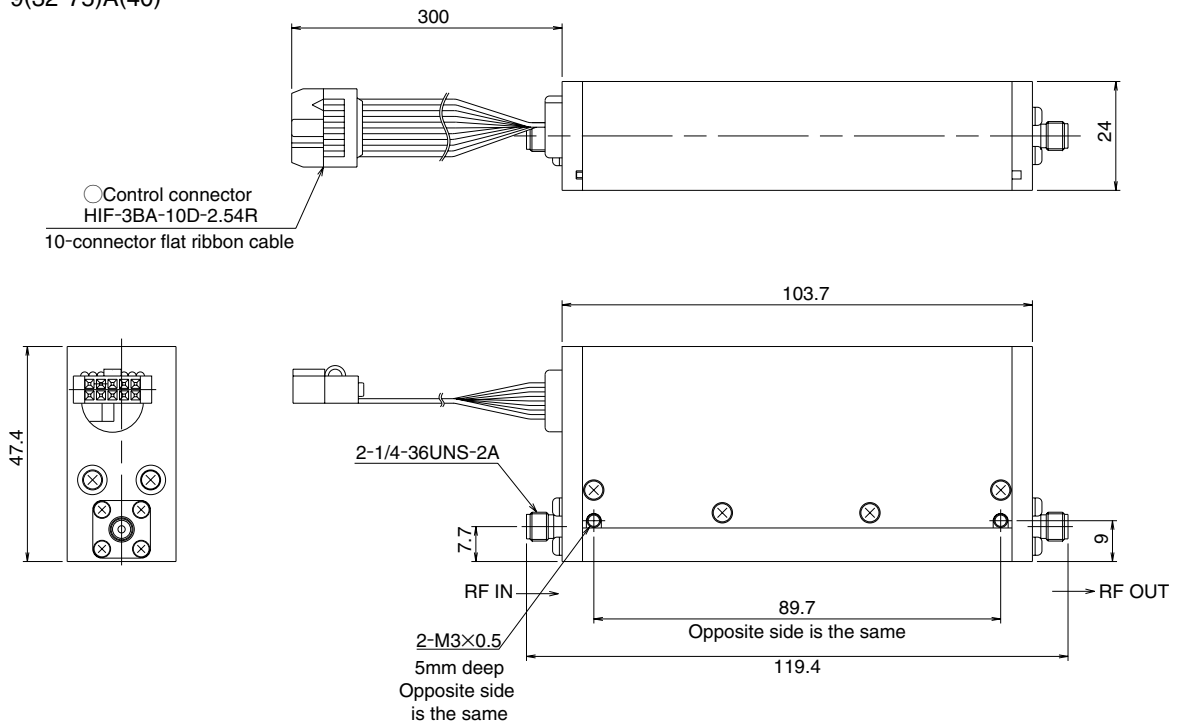

**P-AT Series Programmable Attenuators**

- HIF3BA-10D-2.54R Contact No. P-AT-6(8-70)A(40), P-AT-6(8-65)A(40), P-AT-7(8-75)A(40), P-AT-7(14-75)A(40), P-AT-9(32-75)A(40)  
 ○HIF2B-14-2.54RB Contact No. P-AT-8(26.5-70)A(40)

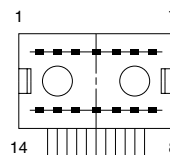
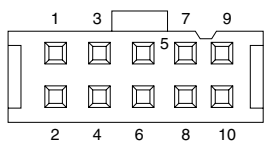

**◆Drive Voltage Contact No.**

Section No. Part No.	DC24V		Ground		Open	
	Contact No.	Cable Color	Contact No.	Cable Color	Contact No.	Cable Color
P-AT-6(8-70)A(40)	9	Red	7	Yellow	—	—
P-AT-6(8-65)A(40)	10	Brown	8	Orange	—	—
P-AT-6(8-70)A(40) P-AT-7(14-75)A(40) P-AT-9(32-75)A(40)	9	Red	Connector Body	—	—	—
	10	Brown	—	—	—	—
P-AT-8(26.5-70)A(40)	6	Red	12	Purple	4	Blue
	—	—	—	—	10	Orange
	—	—	—	—	1,7,8,14	—

**◆Attenuation Change Contact No.(Connect Ground)**

Section No. Part No.	1			2			3			4		
	Contact No.	Cable Color	Attenuation	Contact No.	Cable Color	Attenuation	Contact No.	Cable Color	Attenuation	Contact No.	Cable Color	Attenuation
P-AT-6(8-70)A(40)	1	Black	0dB(Through)	3	Gray	0dB(Through)	5	Blue	0dB(Through)	—	—	—
	2	White	10dB	4	Purple	40dB	6	Green	20dB	—	—	—
P-AT-6(8-65)A(40)	1	Black	0dB(Through)	3	Gray	0dB(Through)	5	Blue	0dB(Through)			
	2	White	5dB	4	Purple	40dB	6	Green	20dB			
P-AT-7(8-75)A(40) P-AT-7(14-75)A(40) P-AT-9(32-75)A(40)	1	Black	0dB(Through)	3	Gray	0dB(Through)	5	Blue	0dB(Through)	7	Yellow	0dB(Through)
	2	White	10dB	4	Purple	40dB	6	Green	20dB	8	Orange	5dB
P-AT-8(26.5-70)A(40)	13	Black	0dB(Through)	3	Gray	0dB(Through)	11	Green	0dB(Through)	—	—	—
	2	White	10dB	9	Brown	40dB	5	Yellow	20dB	—	—	—

○DC Drive Circuit (1 Section)

