

RF Coaxial Switches (DC to 15 GHz)

HCS2 Series



■ Features

1. High Performance and High Reliability

These switches are of the SPDT fail-safe type and have been designed for wide frequency bandwidth, contact voltage strength, power saving, and vibration resistance.

2. SMA Connections

SMA type coupling (Hirose Electric HRM Series) has been used.

3. Environmentally Rugged

A wide variety of tests including temperature and humidity cycles, high temperature power, low temperature power, humidity, vibration, and shock have been conducted and good results were obtained for all.

■ Product Specifications

Ratings	Frequency range Characteristic impedance Maximum Input Power	DC to 15 GHz 50 ohms 15 W	Operating temperature range Operating relative humidity	0°C to +50°C (No freezing) 90% Max.
---------	--------------------------------------------------------------------	---------------------------------	------------------------------------------------------------	-------------------------------------------

Item	Standard	Conditions
1. Contact resistance	Voltage drop of 4 mV max.	1 A DC
2. Insulation resistance	5000 M ohms Min.	500 V DC
3. Withstanding voltage	No flashover or insulation breakdown	100 V AC/one minute
4. Vibration	No electrical discontinuity of 1 μs or more No damage, cracks, or parts dislocation	Frequency of 10 to 55 Hz, overall amplitude of 1.52 mm for 2 hours in each of 3 directions, Frequency of 10 to 500 Hz, acceleration of 49 m/s ² for 3 hours in each of 3 directions
5. Shock		Acceleration of 490 m/s ² , sine half-wave waveform, 6 cycles in each of the 3 axis
6. Humidity	Insulation resistance: 1000 M ohms min. No damage, cracks, or parts dislocation	240 hours at temperature of 40°C and humidity of 95%
7. Temperature cycle	No damage, cracks, or parts dislocation	Temperature: -30°C→+15°C to +35°C→+65°C→+15°C to +35°C Time: 30→5 max.→30→5 max. (Minutes) 5 cycles

● The test method conforms to JIS.

● The temperature resistance cycle, humidity resistance, and shock resistance tests are verification tests of part deterioration and looseness, not tests to be conducted at time of switching or when conducting.

■ Materials

Part	Material	Finish
Outer conductor	Aluminum	Conductive alumite
Inner conductor	Beryllium copper	Gold plating
Connector Body	Stainless steel	Passivated
Female contact	Beryllium copper	Gold plating
Insulator	PTFE	—
Case	Aluminum	Black alumite

■ Ordering Information

HCS 2 - 1 1 0 - F (40)
 ① ② ③ ④ ⑤ ⑥ ⑦

① Series Name: HCS	④ Switching Voltage 1: 12V 4: 17V 2: 20V 5: 10V 3: 26V
② Series No: 2	⑤ Presence of Auxiliary Contacts 0: No 1: Yes
③ Type of Connector 1: SMA (Hirose Electric HRM Series)	⑥ Operation Method F: Fail-safe type
	⑦ (40): RoHS Compliant

HCS2 Series RF Coaxial Switches (DC to 15 GHz)

Specifications

Part Number	HCS2-150-F(40)	HCS2-111-F(40)	HCS2-110-F(40)	HCS2-121-F(40)	HCS2-120-F(40)	HCS2-131-F(40)	HCS2-130-F(40)
Frequency Range (GHz)	DC~15						
V.S.W.R. (Max)							
DC~ 4GHz	1.20						
4~ 8GHz	1.25						
8~12.4GHz	1.40						
12.4~ 15GHz	1.50						
Insertion Loss (Max) (dB)							
DC~ 4GHz	0.2						
4~ 8GHz	0.3						
8~12.4GHz	0.4						
12.4~ 15GHz	0.5						
Isolation (Min) (dB)	60						
Power (W)	15						
Heat Sink Temperature at Applicable Voltage (°C Max)	+50						
RMS Voltage Rating Peak (V)	300						
Switching Time (ms)	30						
Switching Volt Current	DC9~11V 250mA Max	DC11~14V 120mA Max	DC11~14V 120mA Max	DC18~24.5V 120mA Max	DC18~24.5V 120mA Max	DC24~30V 70mA Max	DC24~30V 70mA Max
Durability (Insertion/withdrawal)	30000	10000	30000	10000	30000	10000	30000
Connectors	HRM-J						
Type of Switch	SPDT						
Operation	fail-safe						
Auxiliary contact point	without	with	without	with	without	with	without
Weight (g)	50						
RoHS	YES						

●The value of the switching current is the maximum value at 20°C.

Precautions

- The HCS2 Series is of the fail safe type and designed to make contact by spring force when the drive voltage is not applied. The application of vibrations or shocks in excess of the spring limit may cause resonance of the spring which results in a loss of contact stability and intermittent contact.
- The construction does not prevent the effects of humidity, pressure, or the atmosphere (i.e., gases, oils, and liquids). (Gases, depending on type, may penetrate the spring material inside. The penetration of gases, oils, or liquids that form a film on the contacts may cause changes of the insulation or may cause the contacts to cease to conduct.)
- This product is not magnetically shielded and as such the attention must be paid to the following points.
 - (1) The plate used to mount this product should be made of non-magnetic material. (Aluminum plate is preferable.)
 - (2) Avoid the use of magnetic material and anything that may produce a magnetic field such as a magnet in the proximity of the switches (roughly a 15 mm square).

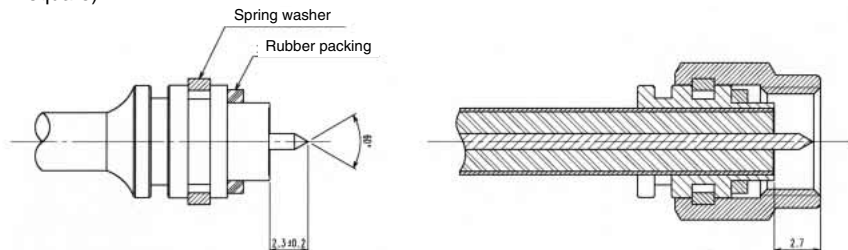

External Dimensions

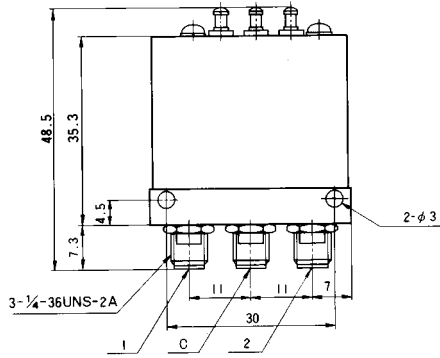
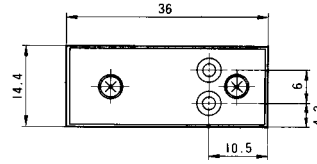
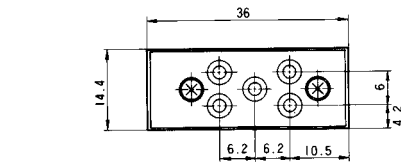

111
HCS2 -121 - F(40)
131

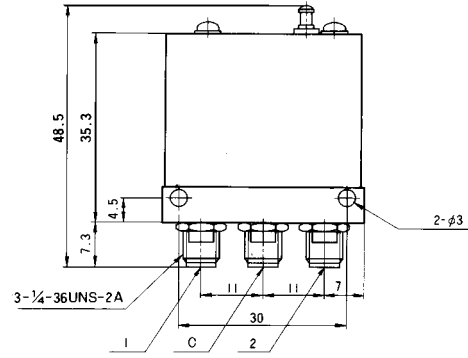

110
HCS2 -120 - F(40)
130
150

Circuit Diagram

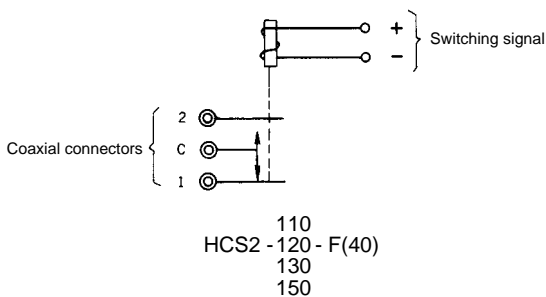
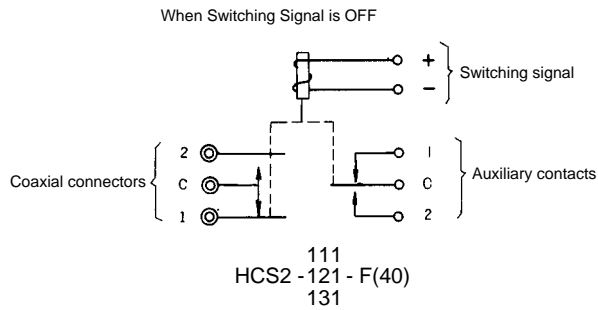

Typical Data

HCS2-110-F(40)

